



T200

OT200 User Guide

OpeMed (Europe) Ltd
www.opemed.net
+44 (0)1252 758855

Introduction

Description

Use

Maintenance

Annual Inspection

Error solving

Warranty statements

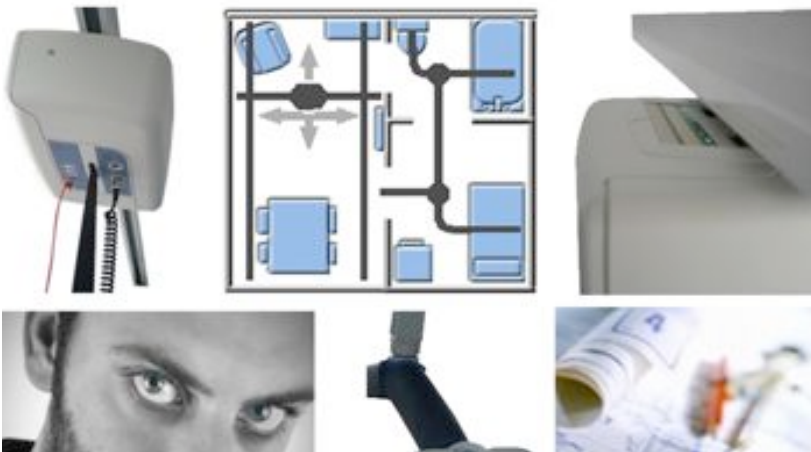

Contents

1	Introduction	
1.1	About this manual	2
1.2	Symbols	2
1.3	Contents of the package.....	2
1.4	The OT200 ceiling hoist.....	3
1.5	Points of attention.....	4
2	Description	
2.1	Overview OT200	5
2.2	Control Panel	5
2.2.1	Charging and life span of the batteries	6
2.2.2	Emergency cord.....	6
2.2.3	Emergency control	6
2.2.4	Indicator lights	7
2.2.5	Connecting the hand-held control.....	7
2.2.6	Connecting the powered hanger bar.....	7
2.3	Hand-held control	7
2.4	Carousel (optional).....	8
2.5	Gate (with X-Y system) (optional)	8
2.6	Hanger bar	9
2.7	Slings.....	10
2.7.1	Sling attachment.....	10
2.7.2	General information about slings	11
2.7.3	Types and sizes of slings	11
2.7.4	Washing instructions slings	13
3	Use	
3.1	Before use.....	14
3.2	Lifting the caretaker with the OT200	14
3.2.1	Lifting from a chair.....	14
3.2.2	Lifting from a bed	15
3.2.3	Attaching the sling to the hanger bar.....	15
3.3	Moving the caretaker with the OT200.....	15
3.4	Taking the caretaker out of the OT200	16
4	Maintenance	
4.1	Cleaning instructions	17
4.2	Daily/Weekly maintenance.....	17
4.3	Annual inspection and maintenance by OpeMed	17
4.4	If the OT200 does not function	17
4.5	Disposal	17
5	Appendix	
5.1	Warranty statements.....	18
5.2	About OpeMed.....	18
5.3	Contact details.....	18
5.4	EG- Statement of conformity.....	19

1.1 About this manual

The aim of this user manual is to enable carers to operate the OT200 and to instruct them on how to carry out small (preventive) maintenance jobs.

This manual deals with the following aspects related to operating the OT200:

- Parts description
- Working principle description
- Step-by-step lifting instructions
- Maintenance of the OT200; to be carried out by the carer

Next to this manual the following documentation is available on the OT200:

- Technical manual. The technical manual is developed for the technical service department and contains:
 - maintenance procedures
 - repair procedures
 - parts lists with order numbers
- Installation manual. This manual can be used during the installation of the systems
 - installation of rail and supports
 - installation of a gate (transition from fixed to mobile rails)
 - installation of carousel
 - part lists with order numbers of all components of the rail system.
- Quick Reference. The Quick Reference guide deals with the main safety and operating aspects relating to the OT200

1.2 Symbols



Attention



Read the manual before operating the hoist



Attention, High Voltage



The producer of the product



With this, the OT200 meets the European Standard, ISO 10535 and the GQ-quality mark T-02, cluster UTT.

1.3 Contents of the package

The delivered package must contain:

- Cassette
- Hand-held control
- Charger
- Charging station
- Technical manual
- User manual
- Quick reference

Remove the packaging from the OT200 and check the contents of the package.

1.4 The OT200 Ceiling Hoist



The OT200 is a ceiling hoist for passive transfers of caretakers. The caretaker can be lifted with the OT200 and it is possible to transfer the caretaker by means of a rail that is attached to the ceiling. The OT200 can be delivered with a mechanical (balanced) or powered hanger bar. The OT200 can also be equipped with an electrical drive for transportation along the rail.

The OT200 can be used for the following transfers:

- From a (wheel)chair to a bed and vice-versa.
- From a (wheel)chair to a toilet and vice-versa.
- From a (wheel)chair to a shower-bath-toilet chair and vice-versa.
- From the floor to a (wheel)chair or bed.

The OT200 cannot be used to active hoist like the James will be



help caretakers with standing up or walking (usually an used for these purposes).

The OT200 complies with the following standards (by KBOH):

- The user can be lifted from a sitting or lying position and will hang in a (semi)sitting position. After transportation of the hoist, the user can be placed back on the supporting element in a sitting or lying position.
- The hoist can be used in combination with wheelchairs, without having to remove foot, leg or arm supports.
- The hoist can be used in combination with an accessible bed, shower window or dressing table at working height. Next to this the hoist can be used for transfers to and from the floor.



With this the OT200 also complies to the demands set by the European Standards, ISO 10535 and the GQ-quality mark T-02, cluster UTT.

Under normal conditions, and with the exception of slings and batteries, the expected life span of the hoist is 10 years (100.000 transfers), provided the hoist is maintained as instructed. Special circumstances, like using the OT200 in humid environments or environments with aggressive vapours can shorten the life time of the hoist.

1.5 Points of attention

- The OT200 is designed to lift and transfer caretakers in combination with an appropriate sling, the OT200 can only be used for this purpose. Any other form of use is not allowed.
- It is not allowed to lift more than 200kg (440lbs.) with the OT200, unless otherwise stated on the lift.
- It is not allowed to lift any object (e.g. a chair or wheelchair) together with the caretaker.
- Special caution needs to be taken when the clips of a sling are attached to the hanger bar, incorrectly attaching these clips can cause a fall of the caretaker and lead to severe injuries.
- Always make sure sufficient space is available above the caretaker before lifting.
- Only use the OT200 in combination with a sling that is delivered by OpeMed. Always contact OpeMed before using alternative slings.
- Treat the lift with care and always make sure the working environment is neat and clean.
- Working with the hoist is only allowed to authorized personnel.
- The OT200 needs at least once a year a periodical inspection.
- Service and maintenance of the hoist is only allowed to be carried out by authorized personnel.
- Only use original parts (supplied by OpeMed) for repairs or replacements.
- Replacing hanger bars or other constructive parts of the hoist is only allowed to authorized personnel.
- Charging the battery always needs to be done in well ventilated, dry rooms. Battery chargers need to be connected according to the installation demands.
- Battery chargers need a periodical inspection at least once a year.
- Never lift the caretaker higher than necessary.
- When deformations occur to the hoist due to incorrect usage or transport, the hoist should not be used anymore, and will have to be sent back to the supplier.
- Avoid collision into end stops at full speed.
- Move the hoist carefully in order to prevent excessive movements of the caretaker.
- Never leave the hoist unattended while loaded. In energy saving mode (after 10 minutes) the load will be lowered slowly.
- Do not use the hand-held control or the hanger bar wires as towing-lines to move the caretaker as this will damage the wiring.

2.1 Overview OT200

The parts in figure 1 will be described in separate chapters.

- | | | |
|---|-------------------------------------|--------|
| 1 | Cassette | page 6 |
| 2 | Control panel | page 7 |
| 3 | Emergency cord | page 6 |
| 4 | Hoisting belt | |
| 5 | Connection socket hand-held control | |
| 6 | Connection socket hanger bar | |

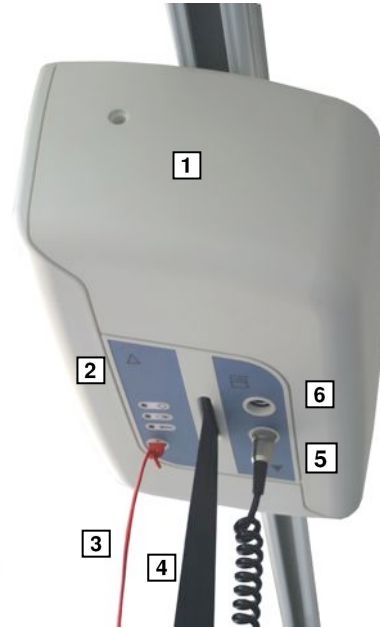

Figure 1 The OT200 cassette

2.2 Control panel

- | | | |
|---|------------------------------|-----------|
| 1 | Emergency cord | see 2.2.1 |
| | Emergency control | see 2.2.2 |
| 2 | Green indicator on-off | see 2.2.3 |
| 3 | Orange battery indicator | see 2.2.3 |
| 4 | Red failure indicator | see 2.2.3 |
| 5 | Connection hand-held control | see 2.2.4 |
| 6 | Connection hanger bar | see 2.2.5 |

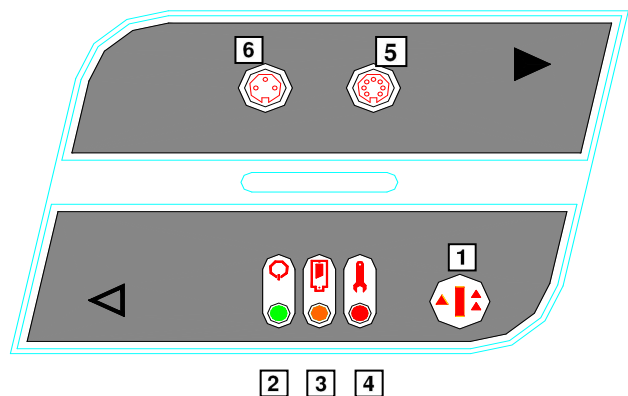

Figure 2 Control panel

2.2.1 Charging and life span of the batteries



In order to maximize the life span of the batteries, it is advised to put the cassette into the charging station when the cassette is not being used.
Always charge the battery when the orange battery indicator is blinking.

Charge the batteries according to the following procedure:

- Make sure the charger is connected to the grid.
- The green indicator on the charger will light up.
- Place the cassette below the charging strips.
- After several seconds charging will start automatically.
- The red indicator on the charger will light up while the battery is being charged.
(The orange indicator on the cassette will light up.)
- The red indicator light will dim when the battery is fully charged.
(The orange indicator on the cassette will also dim.)
- Allow for a charging time of 8 hours.

Capacity

The number of lifting cycles that can be done with a fully charged battery depends on the time per lifting cycle, the lifted weight and the age and condition of the battery.

Discharging

A battery which is not used for a longer time will automatically discharge. Too much discharging of the battery reduces the battery's capacity. This will result in the fact that less lifting cycles can be done with a battery.

2.2.2 Emergency cord

By pulling the red emergency cord the hoist will immediately stop moving. The emergency stop is (de)activated as follows:

Activate emergency stop (figure 3A). Pull the emergency cord.

De-activate emergency stop (figure 3A). Press the red lip to which the cord is attached back into the cassette. After this the cassette will function as normal.



Do not use the emergency cord as an on-off switch. Reactivating the cassette is done with the red lip which is close to the ceiling. The cassette will automatically turn off when it has not been used for more than 10 minutes.

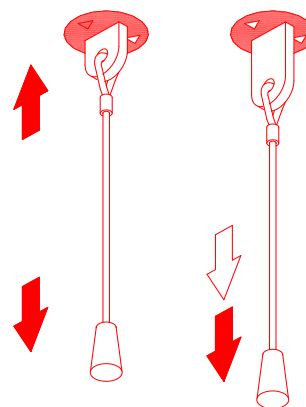

A **B**

Figure 3 Emergency cord

2.2.3 Emergency control

(Only to be used in the case of an emergency)

The emergency control can only be used when there is no other way to get the caretaker out of the hoist. The emergency control uses spare power that is available in the battery. The emergency control can only be used to lower a caretaker and is controlled by pulling the emergency cord. As long as the cord is being pulled down (fig. 3B) the hoist will keep lowering the caretakers.

The OT200 is also equipped with several other safety systems. Examples are the rewind guard and a slack belt guard. A detailed description of these safety systems can be found in the technical manual.

2.2.4 Indicator lights

Green indicator on-off

The green indicator will light up when the cassette is activated. The cassette will automatically deactivate when it has not been used for 10 minutes. The green indicator will dim. The cassette will automatically reactivate when the hand-held control is being used.

Orange battery indicator

The battery indicator tells when the batteries need to be charged. When this indicator starts to blink, the batteries will have to be charged following the description in paragraph 2.1.1. When the hoist is being lowered while loaded, the battery will charge and therefore the orange indicator will light up.

Red failure indicator

When the red failure indicator lights up there is a failure inside the cassette. Immediately alarm your technical service department.

2.2.5 Connecting the hand-held control

The plug of the hand-held control has to be connected to the cassette by screwing the threaded plug into the cassette. (fig. 2-5)

2.2.6 Connecting the powered hanger bar

When the cassette is equipped with a powered hanger bar, the threaded plug of the hanger bar has to be screwed into the cassette. (fig. 2-6) When the hanger bar is connected correctly it can be controlled with the hand-held control.

2.3 Hand-held control



Do not use the hand-held control as a towing line! Stand behind the caretaker and steadily push him or her along the rail. The hanger bar can be used as a handle for transfers.

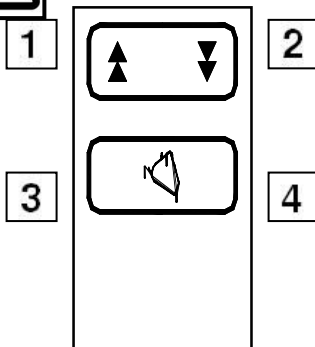

- 1 Hoist up
- 2 Hoist down
- 3 Hanger bar to sitting position
- 4 Hanger bar to lying position

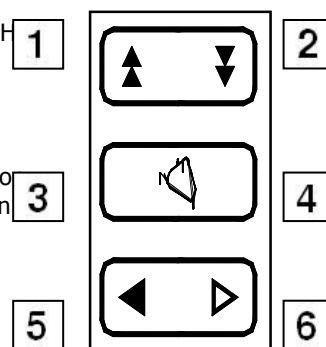

- 5 Move cassette to the left
- 6 Move cassette to the right

Figure 4A 4-function hand-held control

Figure 4B 6-function hand-held control

The OT200 is operated with either a 4- or 6-function hand-held control. This control is used to:

- move the hoist up or down.
- bring the hanger bar from a lying position into a sitting position (only with powered hanger bar)
- move the cassette (only with powered drive of the cassette).

2.4 Carousel (optional)

The system you have chosen might be supplied with a carousel as depicted in figure 5. A carousel creates the possibility of running a cassette along more than one rail. A carousel operates automatically and makes a quarter-turn to the left or the right. A full turn is not possible.

Controlling the carousel is simple:

- Place the cassette in the middle of the carousel.
- After approx. 2 seconds the carousel will turn 90 degrees.
- Drive the cassette out of the carousel.
- If you do not want to make a turn but simply pass the carousel, you should not stop the cassette in the carousel.

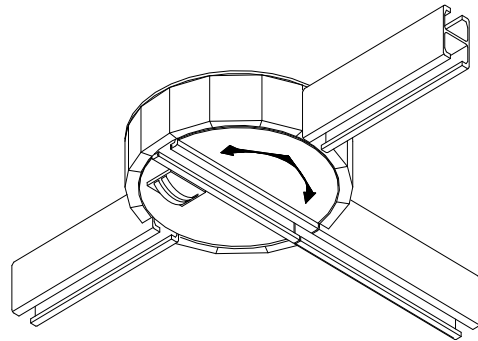

Figure 5 Carousel

2.5 Gate (with X-Y systems)

If your system uses a X-Y system with a transition to a fixed rail then a "gate" is placed where the rails join (figure 6). This gate makes sure that the cassette cannot slide out of the rail when the joints are not aligned. The gate automatically connects the rails and enables a smooth transition from a mobile to a fixed rail.

From fixed rail to X-Y system:

- Move the cassette through the gate toward the mobile rail.
- The rail will de-attach and can be moved.

From X-Y system to a fixed rail:

- Place the cassette in front of the gate.
- Place the rail with the cassette opposite to the other gate. (keep moving slightly)
- The rails will connect and cannot be moved anymore.

The guard will open and the cassette can be moved through the gate.

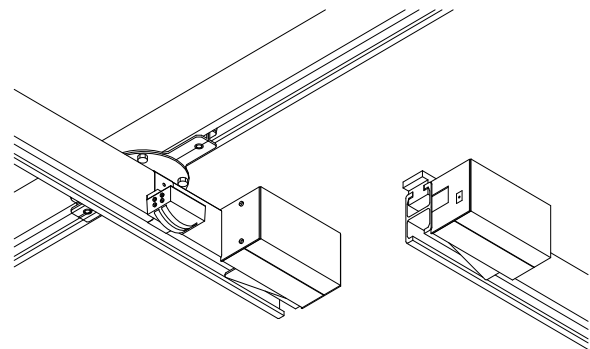

Figure 6 Gate



It is important not to disconnect the gate from the grid. When the gate is on the fixed rail and the power is disconnected the gate will not function anymore and a transfer to the mobile rail is not possible. A technician will have to reset the gate.

2.6 Hanger bar

The OT200 is provided with a hanger bar. The hanger bar is a construction to which the sling (in which the caretaker will take place) can be attached. Several types of hanger bars are available, of which the balanced and the powered hanger bar are the most important types. Both hanger bars create the possibility of transporting the caretaker in a sitting or a lying position. The way this is done is described below.

STANDARD – 2 Point spreader Bar

For use with loop slings (OpeMed and approved competitors)

OPTIONAL EXTRA - Balanced hanger bar

A balanced hanger bar is influenced by the caretaker. The caretaker can bring himself/herself into a sitting or a lying position with simple movements. The balanced hanger bar is most efficient when used with caretakers who have sufficient stability in the hip-joint and sufficient body balance.



OPTIONAL EXTRA - Powered hanger bar

The powered hanger bar is moved from a sitting to a lying position by means of an actuator on the hanger bar. This enables automatic positioning of the caretaker into the desired position, which has high benefits for caretakers with a low hip-stability. The powered hanger bar is controlled by two buttons on the hand-held control. (paragraph 2.3).

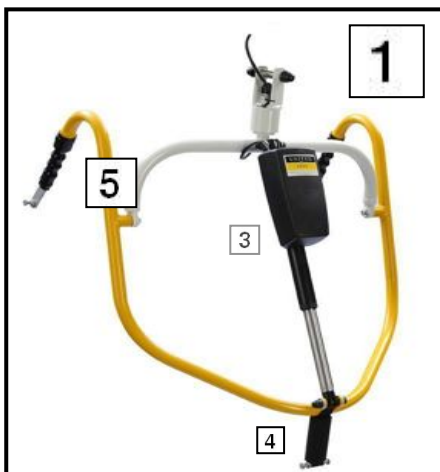

- 1 Sitting position
- 2 Lying position
- 3 Attachment head side
- 4 Attachment leg side
- 5 Hanger bar engine

Figure 7a Sitting position hanger bar

Figure 7b Lying position hanger bar



Do not use the hanger bar cord as a towing line! This might damage the wiring. Stand behind the caretaker and steadily push him or her along the rail. The hanger bar can be used as a handle for transfers.

2.7 Slings

2.7.1 Sling attachment

Sling attachment



Read these guidelines carefully before using the sling. It is ESSENTIAL that you fully understand how to attach the sling in the correct way. Always check the sling for signs of wear or damage before use.

LOOP SLINGS

Attach the loop over the hook, taking care that the same length of loop is attached on either side.

Ensure both leg and shoulder loops are attached (min of 4 loops on any sling)

Always refer to the sling user guide

Always check the weight capacity of the sling and ensure it is not more than the OT200

CLIP SLINGS

- 1 Hold on to the strip on the clip with one hand and pull the large hole in the clip over the attachment point. Check whether the belt on which the sling is hanging is not turned or twisted.
- 2 Take the belt under the clip and pull this down until the clip falls into the secure position.
- 3 The attachment point is now locked into the hole in the top side of the clip.
- 4 Attach all clips in the same way before lifting.



The clip can be de-attached by pulling it upwards and sliding it off the attachment point. Make sure all tension is off the clips before deattaching them in order not to endanger the caretaker.

Attachment point

3.1 Before use

Check the OT200 on the following points before use:

- Check that status of the batteries on the cassette 's display
- Is the emergency stop de-activated?
- Check whether the used sling fits the purpose and the transfer (see tables page 11 and 12)
- Check the condition of the sling and the clips and whether the whalebones are placed
- Carefully place the sling
- Is the caretaker able and comfortable to be lifted?
- The cassette will automatically activate when any button on the hand-held control is pushed

- When using a standard sling, always place the arms of the caretaker inside the sling on the caretakers' lap.
- When using a toilet sling always make sure the arms of the caretaker are outside the sling so that the upper slips with clips pass beneath the arms!
- Always work in a neat and clean environment.
- The OT200 is now ready to be used according to the instructions in this manual.



Always make clear to the caretaker what is happening with every step of the process!
Pay attention to the danger of getting entangled between the hinging points of the hanger bar.

3.2 Lifting the caretaker

Step 3.2.1 Lifting from a chair

- Place the sling behind the back of the caretaker down to the seat. Let the caretaker sit slightly forward during this handling. Make sure the sling is placed with the washing instructions facing to the outside.
- Pull the leg slips slightly forward, this way the caretaker already sits 'inside' the sling.
- Lift one of the caretaker's legs and bring one leg slip of the sling to the inside of the leg. Use the same method to apply the other leg slip.
- If necessary, pull the head side of the sling up to the correct height. The sling will now fit around the caretaker like a 'tank chair'.
- When using a toilet sling apply the circular belt (leg-side) like a belt around the waist of the caretaker. Put the arms of the caretaker through loops on the head-side of the sling.



Toilet slings can only be used with caretakers with sufficient shoulder functioning and body stability.

3.2.2 Lifting from a bed

- Roll-up one side of the sling for about half the total width of the sling.
- Roll the caretaker over on one side, facing the carer.
- Put the sling with the rolled-up side against the back of the caretaker.
- Make sure the sling is placed with the washing instructions facing to the outside (currently the down side).
- Roll the caretaker over the sling onto his/her other side.
- The rolled-up part of the sling will now be on the side of the carer.
- Unroll the rolled-up part of the sling and pull this to the correct position.
- Roll the caretaker back on his or her back, making sure he or she is now lying on the sling.
- Lift one of the caretaker's legs and bring one leg slip of the sling to the inside of the leg.
- Do the same with the other leg slip.
- If necessary straighten the sling in order to make sure the caretaker will lie stable during lifting.

3.2.3 Attaching the sling to a hanger bar

- When lifting from a chair, put the hanger bar in a sitting position (figure 7a page 9).
- When lifting from a bed, put the hanger bar in a lying position (figure 7b page 9).
- Make sure the caretaker is facing the hanger bar



Make sure the belts on the clips are not twisted. If the leg slips are turned the clips can undo themselves.

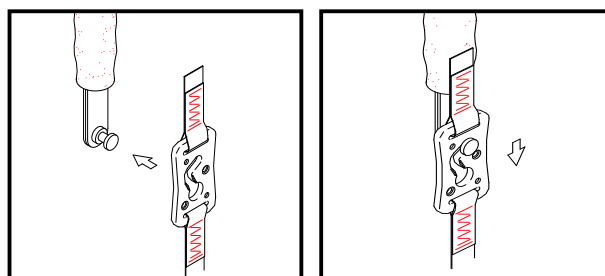

3.3 Moving the caretaker



Do not use the hand-held control as a towing line! This might damage the wiring. Stand behind the caretaker and steadily push him or her along the rail. The hanger bar can be used as a handle for transfers.

- Lift the caretaker by means of the hand-held control.
- While moving, walk with the lift. Stay as close to the caretaker as possible.
- Approach the bed, chair or toilet and then determine the required height for bringing the caretaker to the final position.



Never lift the caretaker higher than absolutely necessary during a transfer.

3.4 Taking the caretaker out of the OT200

Step 1a Lifting towards a bed

- Bring the caretaker into a lying position. Position the caretaker as good as possible above the bed.
- Lower the caretaker onto the bed until he or she completely lies flat on the bed.
- Undo the clips of the sling from the hanger bar and remove the hoist.
- Always use a special bath sling when lifting towards a bath.

Step 1b Lifting towards a (wheel)chair

- Make sure the brake of the wheelchair is applied.
- Lower the caretaker into the chair at low speed.
- Make sure the caretaker is properly positioned into the back of the chair.
- Undo the clips of the sling from the hanger bar and remove the hoist.

Step 1c Lifting towards a toilet

- Follow the same instructions as when lifting to a chair.
- Always use a toilet sling when lifting to a toilet.
- Lower the caretaker's pants to the knees before placing the caretaker on the toilet. Further lower the pants after placing the caretaker on the toilet.
- Undo the toilet sling from the attachment points of the hanger bar while using the toilet.
- Raise the caretaker's pants after the toilet use again to the knees, lift the caretaker and fully raise the pants.



Toilet slings can only be used with caretakers with sufficient shoulder functioning and body stability.

• • • Maintenance 4

4.1 Cleaning instructions

Cassette and hanger bar The best way to clean the OT200 is with a moist cloth. Use normal (house)cleaning detergents.

Slings - See washing instructions, paragraph 2.7.4, page 13. Do not use aggressive solvents when cleaning the hoist or the slings.

4.2 Daily/Weekly maintenance

For normal use the OT200 hardly requires maintenance. We do however advice to pay attention to the following points daily in order to prevent or recognize problems in time.

Action

Clean the hoist:

Wash the slings:

Charge the batteries regularly:

Check whether the hoist operates smooth:

Check for irregular sounds:

Remark

See cleaning instructions paragraph 4.1

See washing instructions, paragraph 2.7.4, page 13.

Make sure the cassette is in the charger when the hoist is not being used.

Alarm the technical service department in order to let them grease or change parts that hinder smooth operation.

Alarm the technical service department



If any doubt occurs about the condition or functioning of the OT200 always alarm the technical service department.

4.3 Annual inspection and maintenance



The hoist needs to be checked once a year according to the NTA-guidelines. This needs to be done by OpeMed or another authorized institution. OpeMed offers you the possibility of an annual inspection by means of an Annual Inspection Agreement.

This mark (figure 12) tells you when the hoist is due for inspection. For more information about inspections you can always contact OpeMed.

Figure 12

4.4 If the OT200 does not function

- Check whether the emergency cord is pulled out (red lip on cassette, see paragraph 2.2.1 op page 6)
- Check whether the batteries are sufficiently charged.
- Check whether the plug of the hand-held control is connected correctly.
- Check whether the plug of the hanger bar control is connected correctly.
- Check whether the belt is slack, if necessary tighten it.
- Check whether the belt has been pulled up too much, the hoist will only go down.
- Check whether the belt has been rolled out too much, the hoist will only go up.
- When the hoist is still not working, alarm the check technical service department.

4.5 Disposal

For disposal the OT200 can be returned to OpeMed. This is also possible with batteries, chargers, slings etc. If you choose to dispose the batteries yourself, be aware of the fact that these batteries are chemical waste.

5.1 Warranty statements

OpeMed gives a 1 year warranty on the OT200. OpeMed does not give warranty on any parts that are exposed to wear, like wheels, slings, hoisting belts or batteries.

This warranty does not apply to damage or failure of the OT200 which is caused by improper or un-professional use or repairs done by others than OpeMed. The judgement on this part lies with OpeMed or an by OpeMed appointed representative.

OpeMed is free to change the product in any way, also not according to this manual. OpeMed does not need to inform the client of this in any way.

5.2 About OpeMed

Transferring and lifting caretakers in the health care sector asks a lot of energy and high professionalism from several parties and especially from carers. OpeMed delivers services and products for people who are involved daily with these transfers. The mobility of the caretaker is our starting point: together with the caretakers and carers, we develop solutions to improve or maintain the caretaker's mobility.

By taking into account and using the moving possibilities of the caretaker we aim at delivering an optimal quality of care and an improvement of labour conditions for the carer.

OpeMed can deliver the following products/services:

- Hoists
- Standing aids
- Bed hoists
- Ceiling hoists
- Accessories for transfer aids
- High-low baths
- Toilet and shower chairs
- Shower trolleys
- Other transfer aids
- Training and advise

The vision, services and products of OpeMed make OpeMed the perfect partner for carers and caretakers.

5.3 Contact details

OpeMed (Europe) Ltd
Riverside Park
Farnham, Surrey
GU9 7UG
United Kingdom
T: +44 (0)1252 758858
F: +44 (0)870 1619681
E: sales@opemed.net
www.opemed.net

5.4 EG - Statement of conformity

We: OpeMed (Europe) Ltd
Riverside Park
Farnham, Surrey
GU9 7UG
United Kingdom

Hereby declare under our own responsibility that the:

The OT200 ceiling hoist system and all attached parts

to which this statement can be applied and which can be put in category 1, complies with the following guidelines:

Guideline 93/42/EEG

and also complies with the following standards or normative documents:

ISO/DIS 14971
EN 10535
NEN-EN-60601-1
NEN-EN-60601-1-2 (EMC)
pr EN 980
NEN 12182

On behalf of OpeMed Ltd,

Place and date : Farnham, Surrey, 06 march 2008

Name and function : N. Kent, director

Signature :

